

Designing a Hoop Building for Feeding Beef Cattle

Shawn Shouse, ag engineering field specialist
W. Darrell Busby, livestock field specialist
ISU Extension
Dallas Maxwell, livestock specialist

Introduction

At the request and urging of beef cattle feeders in southwest Iowa, this project was designed to explore the feasibility of using a hoop building to reduce the facility costs associated with feeding beef cattle in bedded confinement. Design and construction of the facility followed best-available industry recommendations and judgment of the authors and experienced cattle feeders, where innovation was required. Following this initial design and construction, performance of the cattle and facility have been compared with a semiconfinement feeding facility on the same farm.

Materials and Methods

In the summer of 2001, discussions began about the possibility of designing a hoop building for finishing beef cattle. Some criteria and restraints were imposed to accommodate comparison with the existing semiconfinement facility at the research farm. Other criteria were assigned to minimize facility cost and take advantage of the weather conditions at the research farm. Input was gathered from extension specialists, industry representatives, Midwest Plan Service handbooks, cattle feeders, and prior experience at the Allee Research and Demonstration Farm.

Results and Discussion

In the spring of 2004, the final design and specifications were sent out for construction bids. The chosen design used a hoop building 50 ft wide × 120 ft long. Precast concrete feed bunk was located on the outside of the building posts on one sidewall. This arrangement allowed a capacity of

120 head with 50 ft² of building space and 1 ft of bunk space per animal. The building sidewall height was 10 ft. The building length was oriented north-south to allow maximum summer airflow and minimum summer solar gain in the building.

A gravel drive alley for feeding was located outside the building to minimize cost. The feed bunk was located on the east sidewall to minimize winter snow and wind effects. A roof awning with rain gutter was specified for the east side of the building to protect the feed bunk. Several options were considered for closing the space between the awning and the feed bunk, but none were included in the building design.

The building was divided into three pens with separate water drinkers to allow 40-head pens for comparison with the existing semiconfinement facility. This arrangement also allowed performance of the group confined to the center of the building to be compared with the groups having exposure to the open ends of the building. Pens were divided with continuous steel fencing on treated wooden posts. Gates allowed tractor access through the pens along the feed bunk.

A ridge vent 10 in. wide was included in the roof to assist with heat release in the summer. The west wall of the building was lined with lumber to reduce summer afternoon solar gain.

Three gates were installed in the west sidewall to allow movement of cattle from each pen to an outside sorting alley. These gates were outfitted with solid covers and overhead flap doors to provide protection from wind and solar gain. No end-wall enclosures were used on the building. Bedding bales stacked outside the north and south pens have provided wind break protection. The entire building floor was sloped 0.5% (6 in. in 120 ft) to the north. The first 20 ft of floor

adjacent to the feed bunk was treated with 6 in. of reinforced concrete. The first 10 ft of concrete was sloped 0.5 in./ft away from the bunk. The remaining 10 ft of concrete was level. A concrete 5.5 in. × 12 in. step was installed along the bunk. The remaining 30 ft of floor was treated with a layer of geotextile fabric covered with 6 in. of limestone screenings (crushed limestone coarser than ag-lime but finer than common road rock). This floor treatment was approximately one fifth the cost of concrete. The total finished cost of the

building was approximately \$44,400 (\$370/head capacity).

Acknowledgments

Sincere thanks is due to the staff of the Armstrong Research and Demonstration Farm; to Cover-All Building Systems for design and construction assistance; and to local donors: the Wallace Foundation for Rural Research and Development, the Leopold Center for Sustainable Agriculture, USDA, the Iowa Cattlemen's Association, and the Iowa Beef Center for financial assistance.

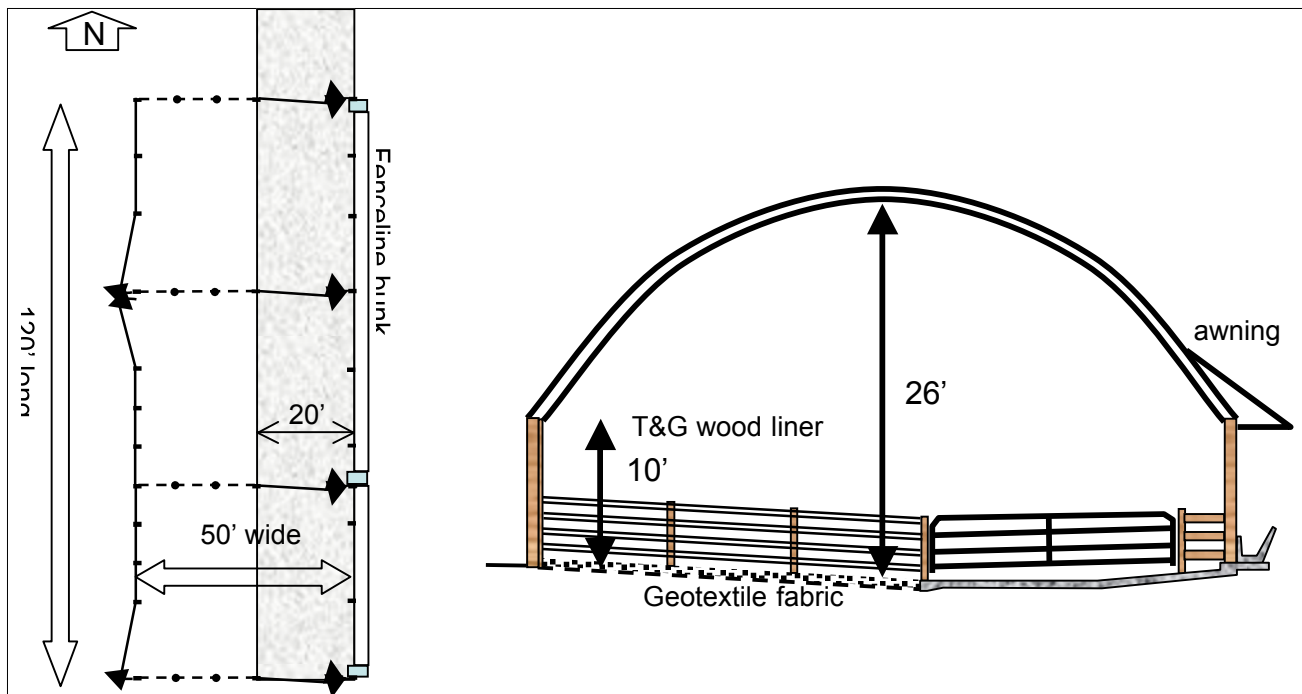

Figure 1. Building floor plan and cross section.